

**User's Manual**



**AC DIELECTRIC TEST SET  
600 Series**

**Model Number 6CP120/60-7.5  
Version 3.5**

**Phenix Technologies, Inc.**  
75 Speicher Drive  
Accident, Maryland 21520

Copyright © Phenix Technologies, Inc

# TABLE OF CONTENTS

<u>DESCRIPTION</u>	<u>SECTION NUMBER</u>
DANGER / GENERAL SAFETY PRECAUTIONS	1
TECHNICAL SPECIFICATIONS	2
CONTROLS AND INDICATORS	3
INITIAL SETUP—MECHANICAL / ELECTRICAL	4
OPERATIONAL VERIFICATION / GENERAL TEST	5
CALIBRATION	6
TROUBLESHOOTING	7
MECHANICAL MAINTENANCE	8
CHECKING OIL PURITY/SPECIFICATIONS	9
TRANSPORTING/STORAGE OF EQUIPMENT	10
CIRCUIT DIAGRAM SYMBOLS	11
ELECTRICAL DIAGRAMS	12
PARTS ORDERING INFORMATION	13
RETURNED MATERIAL	14
PARTS LIST	15
RECOMMENDED SPARE PARTS	16
CUSTOMER COMMENTS / SUGGESTIONS	17

ATTACHMENTS:  
TAD1U Timer Manual

SECTION 1: DANGER / WARNINGS  
**WARNING !!**



**DANGER**

**Grounding of this unit is necessary for the safe operation of this equipment. Disconnect inputs before ungrounding this equipment**

## GENERAL SAFETY PRECAUTIONS



**This equipment can produce POTENTIALLY LETHAL VOLTAGES! Improper operation or test practices may result in injury or death to the operator or surrounding personnel.**

**The operation of High Voltage test equipment should only be performed by personnel familiar with HIGH VOLTAGE testing and safety procedures. The operator of this equipment must be aware of all hazards associated with High Voltage testing. The operator is responsible for himself and others in close proximity of the testing area.**

**Some General Safety Practices for working with High Voltage Test Equipment have been listed below for your reference.**

- **Become familiar with your instrument before performing an actual test**
- **Know your work area, check that all circuits are de-energized and locked out.**
- **Never work alone; always work with another qualified worker.**
- **Mark off entire work area with barriers and warning tape.**
- **Make all personnel aware of your testing activities.**
- **Be aware of dangerous conditions that may arise from energizing a test specimen.**
- **Never modify test equipment, modifications to equipment could introduce an unknown hazard or hinder a designed-in safety feature.**
- **DO NOT operate damaged equipment. Remove power, and do not use the equipment until safe operation can be verified by service-trained personnel.**

**Phenix Technologies, Inc. assumes no liability for unsafe or improper use of test equipment.**

## SECTION 2: TECHNICAL SPECIFICATIONS



### Input

110 - 120 volts, single phase, 50 / 60 Hz, 30 amperes  
 - OR -  
 220 - 240 volts, single phase, 50 / 60 Hz, 15 amperes

### Output Rating

0 - 60 kilovolts, 125 milliamperes  
 0 = 120 kilovolts, 62.5 milliamperes

### Duty Cycle – Capacitive Loading

5 minutes ON / 15 minutes OFF @ 7.5 kVA  
 15 minutes ON / 1 hour OFF @ 5 kVA  
 1 hour ON / 1 Hour OFF @ 3 kVA

### Type of Cooling

ONAN (Oil Natural / Air Natural Convection)

### Operating Ambient Temperature

10 – 40 degrees C

### Output Termination

2" Polished Ball – 60 kV  
 3" x 12" High Voltage Spinning – 120 kV

### Metering - Digital

Output Voltmeter: 3 ½ Digit LCD, Accuracy  $\pm(0.8\%$  of reading + 0.2% of range)  
 Output Currentmeter: 3 ½ Digit LCD, Accuracy  $\pm(0.8\%$  of reading + 0.2% of range)  
 4 Ranges: 0-200 $\mu$ A, 2mA, 20mA, 200mA

### Sizes and Weights

Control/Regulator Section: 21.25" (540mm) W x 16.75" (426mm) D x 13.75" (350mm) H;  
 120V - 52 lbs. (24 kg); 220 V – 58 lbs. (26.4 Kg)  
 High Voltage Section: 19" (482.6mm) W x 19" (482.6mm) D; X 30" (762mm) H;  
 243 lbs. (110.2 kg)

### Additional Equipment

Cart: 22.5" (572mm) W x 29.25" (743mm) D x 50" (1270mm) H;  
 61 lbs. (27.7 kg)  
 Cables: 20 lbs. (9.1 kg)  
 Total Unit Weight: 120V - 376 lbs. (170.7 kg), 220V – 382 lbs. (173.3 kg)

6CP120/60-7.5

# SECTION 3: CONTROLS AND INDICATORS

Control Panel  
Figure 3-1

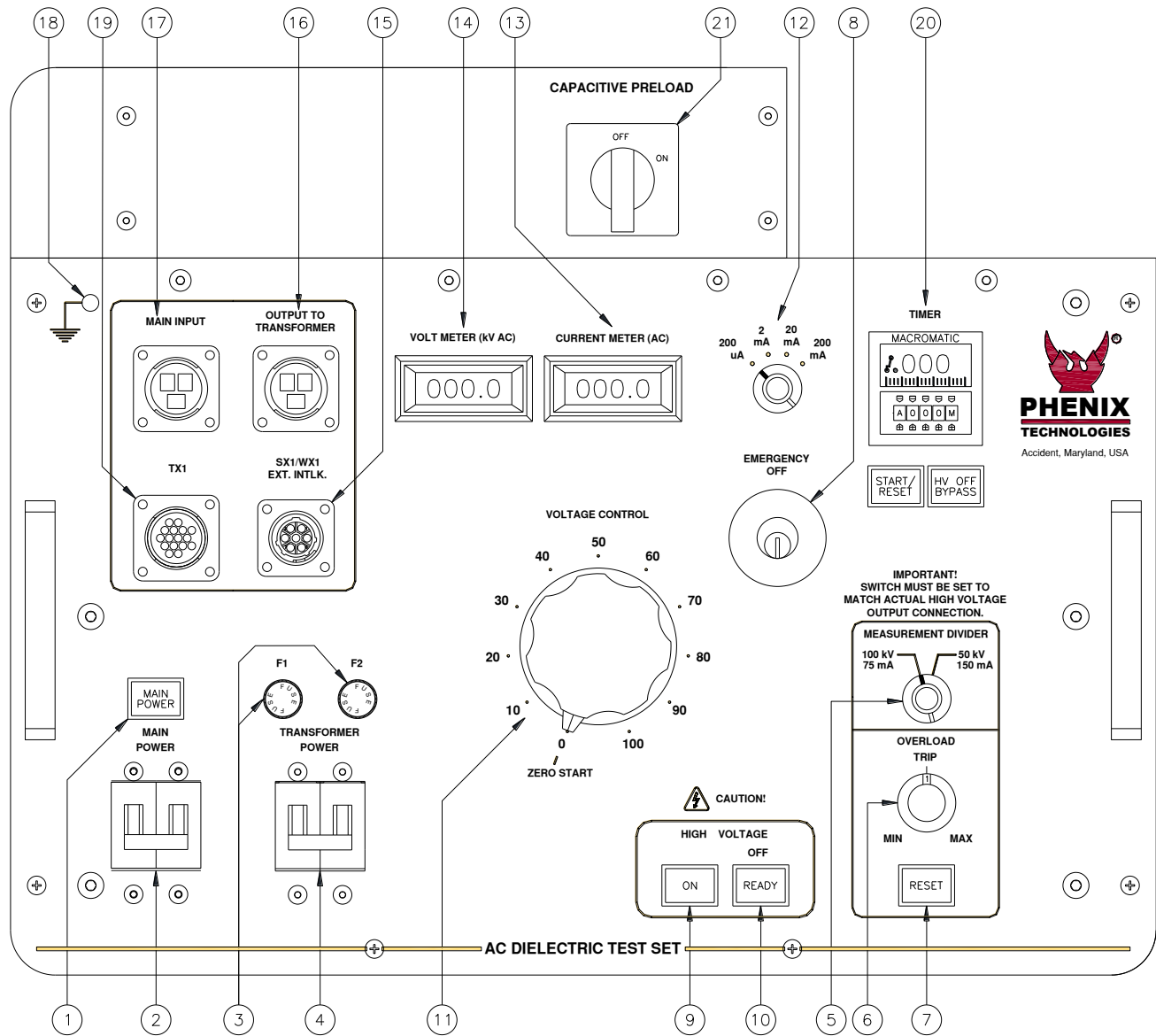

Descriptions are keyed to Figure 1-1.

1. **Main Power Indicator**
2. **Main Power Circuit Breaker**  
Acts as main power switch for unit and provides input overload protection.
3. **F1 (120V) F1, 2 (220V)**  
Control power fuse(s).

## CONTROLS AND INDICATORS

### Control Panel (cont'd)

4. **Transformer Power Circuit Breaker**  
Interrupts power to High Voltage (HV) Transformer. Breaker must be on to activate High Voltage.
5. **Measurement Divider Switch**  
Selects proper overload and voltmeter circuitry for the HV output terminal being used. Match switch setting to output being used on HV transformer.
6. **Overload Trip**  
Use for presetting desired Overcurrent trip setting. Range approximately 10-110% of rated current.
7. **Reset**  
Will light when Overcurrent trip setting is exceeded. Push to reset. Lamp must be extinguished for HV ON.
8. **Emergency Off**  
Push down to stop test immediately. Turn Key switch to activate High Voltage Output.
9. **High Voltage On Switch and Indicator Lamp**  
Turns on HV. when Ready indicator is illuminated.
10. **High Voltage Off Switch and Indicator Lamp**  
Turns HV off, indicator shows when all conditions are met to turn HV ON. (External Interlock closed, Reset Lamp off, Emergency Off Button up, Voltage Control at Zero).
11. **Voltage Control**  
Adjusts Output Voltage and must be set at zero to turn HV on.
12. **Currentmeter Range Selector**  
Switch to select desired current meter range.
13. **Output Currentmeter**  
Displays HV transformer output current. See section 5 for details on current metering setup.
14. **Output Voltmeter**  
Display HV transformer output voltage.
15. **SX1/WX1 External Interlock - Security/Warning Circuit**  
Security Circuit - Provided for user connection of external interlock or auxiliary safety control device such as emergency off switch, gate switch, foot switch, dead man switch, etc. Included plug has shorting jumper installed to complete circuit. Jumper must be removed, and cable connected to user supplied device by user if desired to use this provision. Only non-energized switch or dry relay contact devices may be used. This is a series circuit that must remain closed for high voltage to be activated.

Warning Circuit – Provides power to external warning light circuits. Voltage is provided to different pins depending if HV is no or not. Reference included schematic to see what pins are powered. Unit can be operated without use of this feature.

Security circuit and warning light accessories are available from Phenix Technologies that use this connector. The accessories are able to be “daisy chained” together so that multiple accessories can be used at once. The available accessories include flashing lights, foot switches, and Green\Red-light pole with E-Stop switch.

## CONTROLS AND INDICATORS

### Control Panel (cont'd)

16. **Output to Transformer**  
High Voltage transformer power connection.
17. **Main Input**  
Main input power cable connects here. Connect to facility power
18. **Ground Terminal**  
Ground terminal for control box. The control box should be grounded to the HV transformer ground terminal.
19. **TX1**  
Signal/Metering cable between HV transformer and controls connects here.
20. **Timer**  
Press START/RESET to start the timer after test voltage has been reached. Press START/RESET again to reset timer to the original setting. Press HV OFF BYPASS to allow high voltage to remain on after the timer has expired. Test time can be set using the buttons on the face of the timer to select a time and a range to count to. The timer should be used in mode A. For more information see attachment, TAD1U Timer Manual)
21. **Capacitive Preload Switch (If Applicable)**  
Use to allow full voltage when HV transformer is lightly loaded (< 2.5kVAr). This cannot be switched with HV on. Push-to-Turn feature will open the main contactor and turn HV off if switching is attempted while HV is on.



## CONTROLS AND INDICATORS

### High Voltage Transformer

Figure 3-2

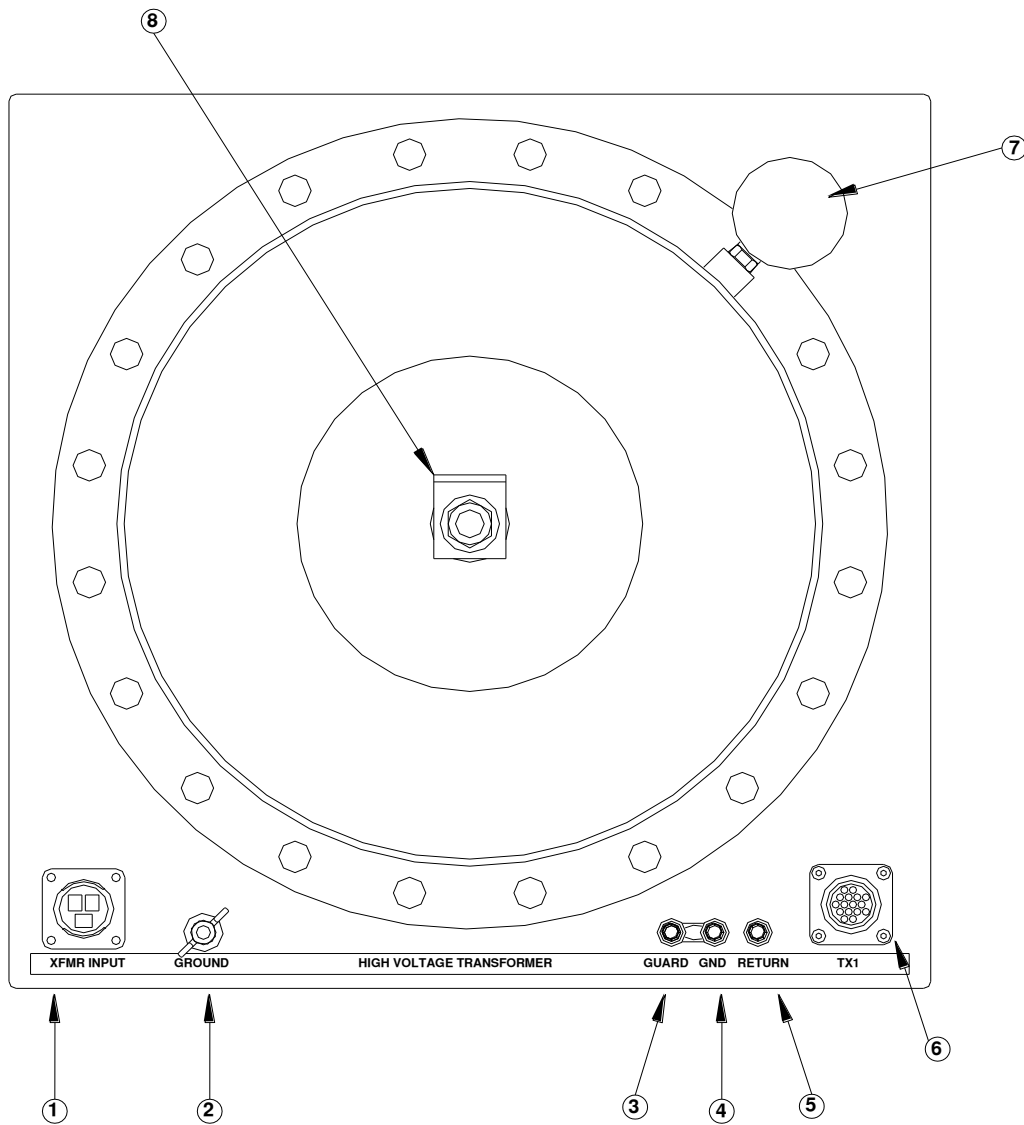

Descriptions are keyed to Figure 1-2:

1. **Power Connector**  
Connect the Power Cable from 'Output to Transformer' connector on control box at this point.
2. **High Voltage Unit Ground Point**  
A Ground cable from facility ground or earth ground must be connected here.
3. **Guard Binding Post (GRD)**  
Currents associated with this connection bypass the current meter (meter bypass connection). See Section 5 for more information on these connections.

## CONTROLS AND INDICATORS

### High Voltage Transformer (cont'd)

4. **Ground Binding Post with Jumper Clip (GND)**  
This binding post is connected to ground. See Section 5 for more information on these connections.  
  
**NOTE:** The Jumper Clip **must always** be connected from Ground to either Return or Guard.
5. **Return Binding Post (RTN)**  
Low potential side of test specimen connects here. This connection routes current through the Current Meter circuit (metered connection point).
6. **TX1 Connector**  
Signal / Metering cable connects from here to TX1 on control box.
7. **60 kV TAP**  
For 0 – 60 kV output at 0 – 125 mA – the Measurement Divider switch on the control panel must be set to 60 kV/120 mA position.
8. **120 kV Tap**  
For 0 – 120 kV output at 0 – 62.5 mA - the Measurement Divider switch on the control panel must be set to 120 kV / 62.5 mA.

## SECTION 4: INITIAL SETUP--MECHANICAL

1. Set up object under test.
2. The area to be used for the test must provide sufficient mechanical and electrical clearances. The approximate weight of each section is available from the nameplates or the Specification Page.
3. If the unit is to be operated indoors, be sure the floor will be strong enough to support the unit. If outdoor operation is to be used, the site for the base must be capable of supporting the unit without any settling that would tilt the assembly.
4. Position the High Voltage Transformer Tank and Control Unit as necessary for operation.
5. Clean entire High Voltage Unit with nothing stronger than ordinary household cleaner to remove all traces of any surface contamination. This cleaning should also include the High Voltage Electrodes.

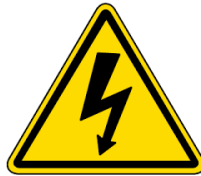

# WARNING !

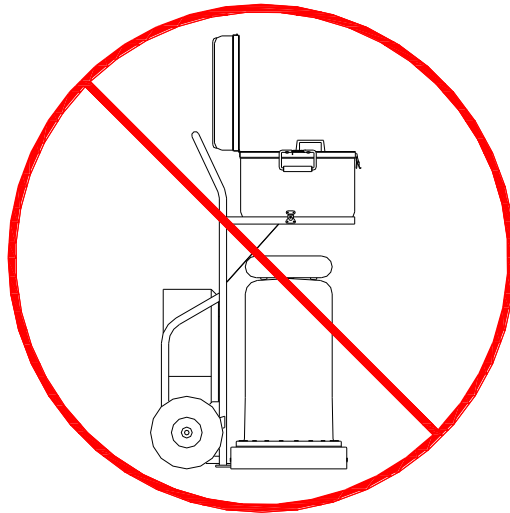

DO NOT OPERATE THE TEST SET  
WITHOUT REMOVING HIGH-VOLTAGE  
TRANSFORMER FROM THE CART.

THE HIGH-VOLTAGE TRANSFORMER  
MUST BE POSITIONED A SAFE DISTANCE  
FROM PERSONNEL AND OTHER OBJECTS.

## INITIAL SETUP / ELECTRICAL



### WARNING:

Ground the output of the High Voltage Transformer until set-up is complete! Be sure the Main Power Circuit Breaker is in the OFF position before proceeding. This equipment should only be operated by personnel familiar with High Voltage testing and safety procedures.

#### 1. Grounding Connections:

- a. Use one of the supplied ground wires for making the ground connection between the control box and high voltage transformer's ground stud.
  - b. Use the other supplied ground wire to connect the facility ground to the high voltage transformer ground stud.
  - c. Connect the test specimen's "low side" or ground to the return terminal on the high voltage transformer using the supplied (Red) return lead.
2. Select the Standard or Guard current metering configuration (see following pages for explanation).
  3. If the external interlock function is to be used, remove the jumper on the male cable end of the SX1 connector and connect the external security circuit at these points.

**NOTE:** The external interlock circuit must consist of a closed loop of dead contacts; an open circuit prevents the high voltage output from being energized. When the control power is on, the external circuit will be energized with 120 volts AC.

4. Connect signal / metering cable between High Voltage Transformer TX1 connector and TX1 connector on the controls.
5. Connect the power cable from the High Voltage Transformer to the 'Output to Transformer' connection on the control box.
6. Connect the test object to the output termination of the high voltage transformer. Ensure that the connection is applicable for test level and type of test and that the connection has sufficient safety clearances for the voltage rating. Two high voltage output connections are possible:

60kV, 125mA: The 60kV tap is located on the side of the high voltage cylinder. Set the Measurement Divider switch (See Section 4) to the 60 kV/125mA position when using this output. This sets the metering and overload properly for the output being used.

120kV, 62.5Ma: The 120kV tap is located on the top of the high voltage cylinder. Set the Measurement Divider switch (See Section 4) to the 120 kV/62.5mA position when using this output.

A wire can be used to make this connection; however, for best results (less corona leakage current), route a wire down the center of a one-inch diameter pipe (either aluminum or copper), and solidly connect the ends of the wire to the output tap and the test specimen. The pipe should also be solidly connected at each end.

7. Connect the input main power cable to the Main Input connection at the control box and then to the facility power source.

## INITIAL SETUP / ELECTRICAL

### CURRENT METER GUARD CIRCUIT:

There are three terminals on the base of the high voltage transformer: white GRD (Guard), green GND (Ground), and a red RTN (Return). There is a metal jumper that must always be connected between either the GND and GRD terminals or the GND and RTN terminals.

Refer to Figure 4-1 on the next page:

#### Standard Mode:

In this configuration the current meter measures all leakage current from the HV electrode. Measured current includes specimen leakage and stray leakage.

#### Guard Mode:

In this configuration only the leakage current from the HV electrode through the test specimen to the RTN terminal is measured by the current meter. Any stray leakage current to ground is guarded out (bypasses the meter) and is not measured. Stray leakage current to ground can be from several sources. The HV transformer has some capacitive leakage to ground. The HV connection might have some leakage due to partial discharge (corona). The test specimen might have some leakage current to ground and your application requires that this “stray” leakage not be measured.

#### Electrical Setup:

In either configuration, the high voltage transformer’s ground stud must always be connected to earth ground. The GND terminal referred in the following two paragraphs is internally connected to the ground stud.

For standard current measurement, connect the jumper between the GND and RTN terminals. Connect the test specimen return (low voltage side) to the RTN terminal.

For guarded current measurement connect the jumper between the GND and GRD terminals. Connect the test specimen return (low voltage side) to the RTN terminal. Do not connect the specimen return to ground. The test specimen must be totally isolated from ground.

## INITIAL SETUP / ELECTRICAL

### Currentmeter Guard Circuit

Figure 4-1

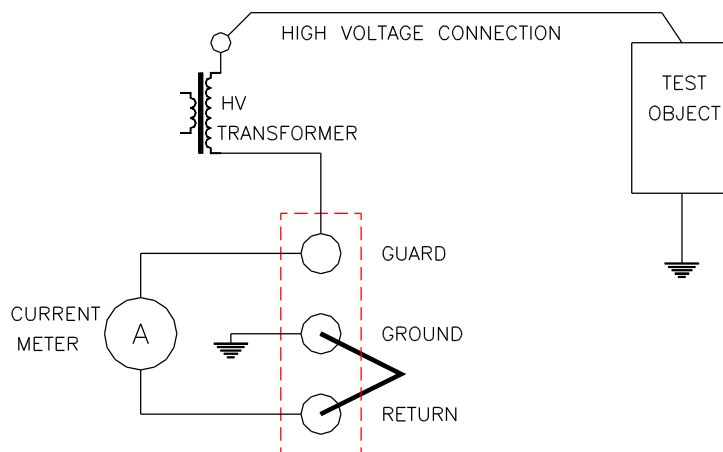

STANDARD MODE

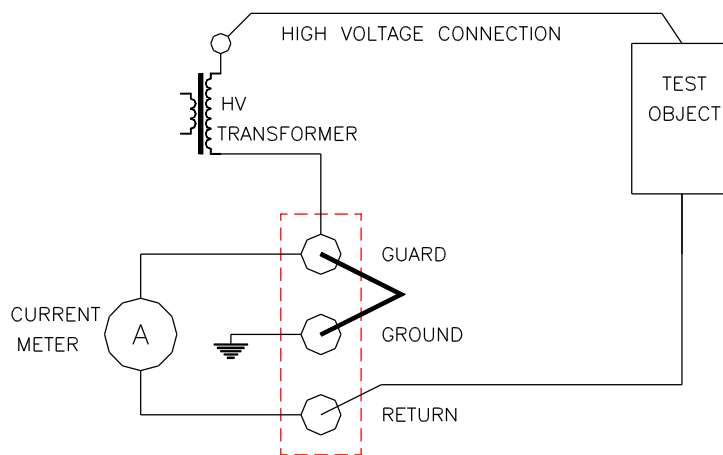

GUARD MODE

## SECTION 5: OPERATIONAL VERIFICATION PROCEDURE



### **WARNING:**

**This equipment should only be used by personnel familiar with High Voltage testing and safety procedures.**

1. Make sure that Main Power Circuit Breaker on the Control Panel is in OFF position.
2. Make sure that all electrical connections have been properly made between the Controls and High Voltage Unit, including grounds. Remove Ground from HV Transformer output if it is grounded. There is to be no connection to the high voltage outputs at this time. There must be adequate clearance from the High Voltage Unit to allow voltage to be raised safely.
3. Place currentmeter in "RTN" mode. (Connect jumper of "RTN/GND/GRD" binding posts between "RTN" and "GND").
4. Connect Main Input Power Cable to Controls and to Power Source. Switch the Main Power Circuit Breaker on the Control Panel to On position. Main Power indicator lamp should illuminate. Check that the Transformer Power Breaker is on, Emergency Off button is pulled up, Voltage Control is at Zero, Reset Lamp is Off, and EXT INTLK CKT is complete or has shorting jumper in place. HV Off lamp should be illuminated.
5. Turn Capacitive Preload ON.
6. Press HV On switch. Indicator lamp should illuminate. Press the HV Off switch. HV On indicator lamp should extinguish and HV Off / Ready lamp should illuminate.

**NOTE:** The following conditions **must be** met before High Voltage will engage: External Interlock loop must be closed, Emergency Off switch must be closed (mushroom button up), Overload Reset Lamp must be off, Voltage Control at Zero Start, and Transformer Power Circuit Breaker on.

7. Set Measurement Divider Switch to 120 kV / 62.5 mA.
8. Press the HV On switch.
9. Manually raise the Voltage Control dial on the Control Panel to approximately 50 (50%). Voltmeter should indicate voltage change, and show approximately 54 to 66 kV.
10. Select 60 kV / 125 mA on Measurement Divider Selector Switch. At 50 on Voltage Control Dial, voltmeter should read approximately 27 to 33 kV.
11. Return Voltage Control to Zero. Press HV Off switch.
12. Turn Main Power Circuit Breaker off and connect a short between the 50kV High Voltage Output and Ground. Measurement Divider Switch is to be set at 60 kV / 125 mA.
13. Set Overcurrent Trip to low (1) setting.

## OPERATIONAL VERIFICATION PROCEDURE

14. Turn Main Power Circuit Breaker on. Press HV On switch and slowly raise voltage with the dial on the Control Panel. Output Current Meter will indicate, and at approximately 10% of output current rating, the High Voltage will trip off and the Overcurrent Indicator Lamp will illuminate. With the front panel Overload Selector Switch set at 60 kV/125 Ma and current range switch set to 200 mA, the trip point should be at approximately 12.5 mA. Return Voltage Control to zero and turn off Main Power Circuit breaker.
15. Move short from 60 kV output to 120 kV output and ground. Repeat step 13. Unit should trip off at approximately 6.25 mA.

**NOTE:** Do not attempt to check 110% level of current trip under shorted output conditions. Rated output currents are only available through a capacitive load of sufficient value. Shorted current values should never exceed 50% of rated currents for the High Voltage Tap being used. If desired to test at 110% of current rating, the 60kV/125 mA tap must be connected to a High Voltage Capacitor of approximately 6 nanofarads rated at 60 kVAC or higher (for 60Hz).

16. Turn Off Main Power Circuit Breaker on Control Panel.

**END OF OPERATIONAL VERIFICATION TEST!**



## OPERATIONAL VERIFICATION PROCEDURE

### General Test Procedure:

1. Make sure that Main Power Circuit Breaker on the Control Panel is in the Off position.
2. Make sure that all electrical connections have been properly and securely made and that the test specimen is properly connected to the High Voltage Transformer (refer to Initial Set-up Procedures). Make sure the Guard / Ground / Return Jumper Clip is set properly for test being performed. Make sure that all personnel are clear of danger and that test area is clearly marked.
3. Connect Input Cable to Controls and to Power Source. Switch the Main Power Circuit Breaker on the Control Panel to the On position.
4. Set Measurement Divider switch to the position that matches the High Voltage output being used.
5. Set Overload Trip dial to desired trip-out level. (NOTE: In setting this device, it is important to take into account the capacitive current that the sample under test will require. Set the dial to a high enough value to preclude false failure indications. If this value is not known, it is recommended that the dial be left in a higher setting.)
6. Turn the Capacitive Preload ON for loads of less than 2500 VA (capacitive). (If Applicable)
7. Press the HV On switch. (NOTE: The following conditions must be met before High Voltage will engage: Security Circuit Loop must be closed, Emergency Off Switch must be closed (mushroom button up), Overload Reset Lamp must be off, Voltage Control at Zero Start, Transformer Power Circuit Breaker on, and Ready lamp illuminated.)
8. Raise the manual Voltage Control knob on the Control Panel until desired test voltage level is reached. Keep voltage at desired level for required duration. Record data if desired.
9. After completion of the test, manually return the Output Voltage to zero or its lowest level via the Voltage Control knob.
10. Press HV Off momentary switch.
11. If during the test a failure should occur or if the Overcurrent Trip setting is exceeded, the High Voltage will automatically shut off. In order to regain High Voltage, the Reset pushbutton must be pressed and Voltage Control knob returned to Zero.

## SECTION 6: CALIBRATION

### WARNING:

Calibration should only be done by persons familiar with High Voltage testing and safety procedures.

All calibrations have been done at the factory. Periodic calibration of the output voltmeter and output currentmeter should be done annually.

NOTE: Refer to Electrical Diagram Section for schematics pertaining to the model number of your test set.

### Locating the Calibration Adjustments

The calibration points are shown in the following diagram.

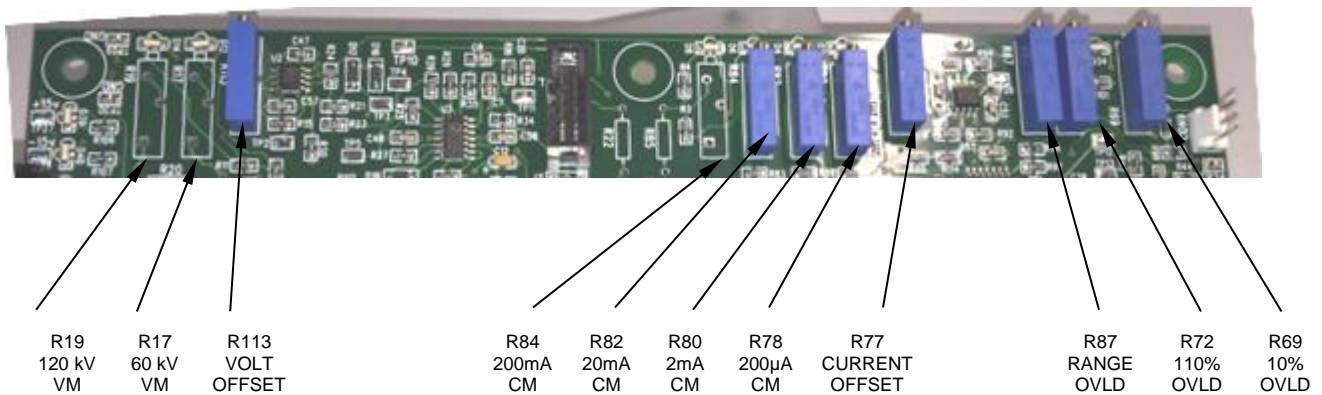

#### 1. Output Voltmeter

Connect a precision high voltage voltmeter across the output to ground on 60 kV output, with Measurement Divider switch set to 60 kV. Raise the output to approximately 80% of the output rating. Adjust the reading on the panel meter (M2) by means of potentiometer R17 to a corresponding reading. Repeat procedure with precision high voltage voltmeter connected between the 120 kV output and ground with the Measurement Divider switch set to 120 kV. Adjust R19 to match precision voltmeter at 80% of output rating.

#### 2. Output Currentmeter

It is necessary to connect adequately rated High Voltage loads (isolated from ground) to the high voltage unit that will allow each full range current to be drawn at approximately 15% or higher output voltage. This allows sufficient resolution to adjust current levels. All ranges can be calibrated from 60 kV output.

Place Binding Post Configuration in GUARD MODE. (Jumper clip is installed between "GRD" and "GND" posts.)

Connect a precision ammeter between the low potential side of the appropriate high voltage load and the "RTN" post. Select the 200 uA meter range. Raise the output to approximately 80% of the range rating. Adjust the reading on the panel meter (M1) by means of potentiometer R78 to a corresponding reading. Repeat for 2 mA, 20 mA and 200 mA ranges adjusting R80, R82 and R84, respectively. (High Voltage load will need to change when changing range).

NOTE: An optional method is to use current injection between RTN and GND (Guard Mode).  
**Do not turn High Voltage on for this method!**

## CALIBRATION

### 3. Overcurrent

This calibration should not need adjustment (factory adjusted). If the Overcurrent Circuit is out of calibration, perform the following steps. To recalibrate the Overcurrent Circuit with the High Voltage Unit it will be necessary to connect an 8 nanofarad capacitor rated at 60 kVAC or higher to the 60 kV / 125 mA output of the High Voltage Unit. If the capacitor is isolated from ground at the low potential end, the low potential end can be connected to the RTN post. The Guard Post Jumper may be connected to GRD (Guard Mode). If the low potential end of the capacitor is grounded, the Ground Post Jumper must be connected to RTN post.

- a. Set front panel Measurement Divider switch to 60 kV/125mA. When current trip dial is set to minimum (1) current trip level should be approx. 12.5mA. When dial is set to maximum (11) trip level should be approx. 137.5mA.
- b. Set the Overload Trip potentiometer (R15) on the front panel to "1" and the Current Range switch to 200 mA.
- c. Turn on HV On and adjust the output current slowly until 10% of rated current is displayed on the current meter (12.5 mA).
- d. Adjust potentiometer R69 until the Reset lamp illuminates and high voltage is shut off.
- e. Set the Overcurrent Trip potentiometer (R15) on the front panel to "11."
- f. Turn on HV On and adjust the output current slowly until 110% of rated current is displayed on meter (137.5 mA).
- g. Adjust potentiometer R72 until the Reset Lamp illuminates and high voltage is shut off.
- h. Repeat steps "b" through "g" if necessary, until both settings are calibrated.

### 4. Range Overcurrent:

R87 sets an overcurrent for the ranges and should be set to trip at approximately 112% of full range current on medium range setting with current trip potentiometer set at "11."

### 5. Voltage offset adjustment (R113):

The voltage offset should be done with the voltage output lead connected to board ground. This typically can be done by connecting the output to the guard terminal. Once connected, the offset should be adjusted until the output meter reads nearest to zero. This offset adjustment should be done before adjustments to the voltage ranges are made. Test point T10 may also be used to make this adjustment.

### 6. Current offset adjustment (R77):

The current offset should be done with the current input connected to board ground. This typically can be done by placing a jumper from the guard to the return terminal. Once jumped, the offset should be adjusted until the output meter reads nearest to zero. This offset adjustment should be done before adjustments to the current ranges are made. Test point T37 may also be used to make this adjustment.

## SECTION 7: TROUBLESHOOTING

### General

If the controls do not operate properly after having been used according to the instructions, the following process may help.

- ◆ Check main facility input power to the test set.
- ◆ Check all control and switch settings.
- ◆ Check indicating lamps. (Spare lamps are available through Phenix Technologies.)
- ◆ Check Fuse F1 and F2
- ◆ Check operation of main power circuit breaker (CB1). Main Power lamp should be on.
- ◆ Check Transformer Power circuit breaker.
- ◆ Check all plug connections, internal and external, on the test set.

### Specific Problems

#### 1. High voltage cannot be turned on?

- Emergency OFF has been pressed – pull switch button up.
- External interlock is open (SX1).
- Voltage Control dial is not in zero start position.
- Protection circuit (Overload Trip) is not Reset.
- Transformer Power circuit breaker is off or faulty.
- Faulty HV On or Off switch.
- Faulty relay contacts.

#### 2. Voltage control inoperable?

- Transformer Power circuit breaker faulty.
- Problem with power cable between Controls and High Voltage Unit.
- High voltage is not on (K1 or K3 not energized or see number 1 above).
- Faulty regulator T1.
- Faulty step-up transformer in high voltage unit. (T3001).

#### 3. Overload Trip inoperable?

- Improper sensitivity (adjust Current Trip (R15) on front panel).
- Defective U13.
- Check the +15 volts DC and -15 volts DC regulator (U16, U17).
- Check LP4 (RESET) and relay K7 on PCB 1387.

# TROUBLESHOOTING

## Specific Problems (cont'd)

### 4. **Currentmeter inoperable?**

- Binding post jumper clip installed between ground and guard with a grounded test object.
- Connection between currentmeter and high voltage test specimen return connected improperly.
- Meter damaged
- Faulty TX1 interconnect cable.
- Damaged or inoperative range switch or wiring.
- Faulty Circuit on PCB1387.

### 5. **Voltmeter inoperable?**

- Faulty TX1 interconnect cable.
- Meter damaged.
- No high voltage present at transformer output.
- Damaged or inoperative Measurement Divider Switch.
- Faulty circuit on PCB1387.

### 6. **No output voltage from high voltage section?**

- No input to voltage regulator section, possible problems with K1 or K3, regulator (T1), or with Transformer Power circuit breaker.
- Internal connection broken.
- High voltage winding of T2 short circuited.
- Refer also to 1 and 2 above.

## **SECTION 8: MECHANICAL MAINTENANCE**

### **General**

No solution or chemical stronger than an ordinary household cleaner should be applied to the cabinet area of this unit. Care must be used when cleaning the meter faces and console panel. Abrasives may remove printing and descriptive titles. When cleaning, always disconnect unit from power source. Never attempt to clean inside the unit as the cleaning solution may cause damage to the electronic components.

### **High Voltage Transformer**

#### **Surface**

All surfaces are finished with heavy duty paints and will provide adequate protection against the elements in normal use. It is recommended that the finish be wiped down for longer life and also, for proper electrical operation of the unit. Also inspect all fabrication joints for oil leakage. If a leak is found, check hardware for tightness or consult Phenix Technologies Service Department.

#### **Control Box / Regulator Section**

At least once every year, the control assembly should be removed for inspection of the regulator assembly and other parts. If dust and dirt are present, cleaning with a dry brush and air hose should be sufficient. Inspect the voltage regulator contact surfaces for any signs of burning or wear. The brushes are the carbon type and are constructed to provide a 1/8" wide contact point. If they are worn down so as to be nearing (approximately) 1/32" at the wider part of the brush, they should be replaced.

The only other mechanical maintenance needed on the control box is that it be kept clean.

#### **Transformer Oil Maintenance**

At time intervals, ranging from six months to one year, the oil purity (see next page) should be checked in the high voltage transformer to verify its reliability. If the transformer is subject to adverse weather conditions or an oil leak develops, the oil purity should be checked regularly.

## SECTION 9: CHECKING OIL PURITY

NOTE: The complete specifications for the oil used by Phenix are provided at the end of this section.

1. The most reliable means of determining the purity of the oil in the field is to test the dielectric strength. Test sets for this purpose available on the market differ in design, particularly in the shape of the electrodes and the test container.

Tests on samples from the same oil carried out with electrodes of different types give different breakdown values for the same distance between the electrodes. Oil test values should therefore always be accompanied by information about the type of test gap used. The most common types of test gaps are:

- a. Cylinder gap.
- b. Spheres, 12.5 m in diameter.
- c. Flat discs, 25 mm in diameter.
- d. Segments for spheres, 35 mm in diameter, radius of sphere 25 mm.

Phenix employs for field testing Gap C, flat discs, which is per ASTM specification D-877.

2. Regardless of which type of test gap is used, it is important that the container and electrodes be well cleaned and dried before oil filling. Cleaning should be done per the instructions with the oil testing equipment.

3. Sample the oil at the top of the transformer. Phenix recommends a minimum test level of 30 kV when using the ASTM D-877 test procedure. If the oil tests lower than this, consult the Phenix Technologies Service Department for recommendations.

If action is required, it is recommended to replace the oil with new oil. Alternately, the oil can be removed and re-purified, then replaced. Either action then requires that the High Voltage Unit be processed in a vacuum chamber after refilling to remove any air and moisture.

### 4. Oil Specifications

Transformer oil is a high quality insulating oil specially refined and formulated to meet the exacting requirements of major electrical equipment manufacturers and users. It also meets Federal Specification VV-I-530a.

High quality mineral-based transformer oil is recommended as the insulating and cooling medium for oil-immersed transformers. It is also recommended for arc-forming apparatus such as switches, circuit breakers, tap changers, reclosers, and fuses. General Characteristics of transformer oil include:

#### a. High Dielectric Strength:

Transformer Oil has high electrical insulating values as shown by their dielectric strengths of over 30,000 volts.

#### b. Excellent Oxidation Stability:

Excellent oxidation stability and high resistance to sludging provide protection, particularly where high temperatures are likely to be encountered. These products are specially refined to ensure long time service with a minimum of maintenance.

## CHECKING OIL PURITY

### c. Freedom From Contaminants:

Absence of organic acids, corrosive sulfur, and other foreign materials, which might affect metals or insulation, ensures long life for the oil as well as the electrical units.

### d. High Interfacial Tension:

High interfacial tension shows the absence of soluble polar contaminants. Refinery sealed containers assure maintenance of purity in transit.

### e. Good Heat Transfer Properties:

Good circulation and rapid transfer of heat from the coils to the cooling fins are assured by low viscosities at all operating temperatures.

## Specifications

(Typical Test Data for Transformer Oil)

TEST	METHOD	UNITS	SPECIFICATION
Moisture	ASTM D1533	Mg/kg	35 max
Color	ASTM D1500	ASTM	0.5 max
DDF (Power Factor) @100°C	ASTM D924	0.3 max	0.3 max
Breakdown voltage (2mm gap)	ASTM D1816	kV	35 min
Inhibitor Content	ASTM D2668	%w/w	0.30 max
Interfacial tension	ASTM D971	dynes/cm	40 min
Density @15°C	ASTM D1298	g/ml	0.91 max
Viscosity @ 100°C	ASTM D445	cSt	3.0 max
Viscosity @ 40°C	ASTM D445	cSt	12.0 max
Viscosity @ 0°C	ASTM D445	cSt	76.0 max
Refractive Index	ASTM 1218	Units	
Carbon N%	ASTM D2140	%	
Carbon A%	ASTM D2140	%	
Carbon P%	ASTM D2140	%	
Corrosive Sulfur	ASTM D1275B		Noncorrosive
PCBs – Detection Unit 1 mg/kg	ASTM D4059	mg/kg	Not Detected
Flash Point	ASTM D92	0°C	145 min



## SECTION 10: TRANSPORTING / STORAGE OF EQUIPMENT

In some instances, there is a requirement for transporting the equipment from one location to another for on-site field testing. If such conditions prevail, the following precautions should be adhered to.

### 1. Control Box / Regulator Section

Anchor sufficiently to prevent movement during shipment, and cover with a canvas or other protective covering to prevent damage during transport.

### 2. Interconnect Cables

Cover the connectors, both male and female ends, to prevent foreign matter from entering.

### 3. High Voltage Transformer

Anchor sufficiently to prevent movement during transport, and cover with a canvas or other protective covering to prevent damages during transport. Prior to operation, all insulating materials should be cleaned. Protective caps should be in place on connectors.

## STORAGE OF EQUIPMENT

If the equipment will be stored for a prolonged period, the following precautions are recommended.

1. The equipment should be covered and kept in a warm, dry environment (95% maximum humidity, 5 to 50 degrees C).
2. If the high voltage transformer is to be stored outdoors, it should be completely covered to prevent damage from environmental conditions.
3. In no case should the control box be stored outdoors
4. Prior to placing the equipment back into operation, all aspects of the maintenance schedule should be strictly adhered to.

## SECTION 11: CIRCUIT DIAGRAM SYMBOLS

CIRCUIT DIAGRAM SYMBOLS  
SYMBOLS POUR SCHEMA DE CIRCUIT  
SYMBOLE ZU SCHEMA

REF	SYMBOL	DESCRIPTION	DESCRIPTION	BEMENKUNG
A		Amplifier	Unite d'amplificateur	Verstärker
ARSR		Surge Arrestor	Parafoudre	Ueberspannungsableiter
C		Capacitor	Condensateur	Kondensator
BSHG		Bushing	Tranversée	Durchfuehung
C		Electrolytic Capacitor	Condensateur electrol	Eleckrolytik kondensator
F		Fuse	Fusible	Sicherung
CT		Current Transformer	Transformateur de Courant	Stromtransformer
CB		Circuit Breaker	Intérupteur	Unterbrecher
K		Relay, Contactor	Relais, Contacteur	Relais, Schütz
L		Inductor	Self	Drossel, Spule
MOT		Motor	Moteur	Motor
MOV		Movistor	Parafoudre	Movistor
NE		Neon	Parafoudre	Ueberspannungsableiter
LP		Lamp, Indicator	Lampe	Meldeleuchte
R		Resistor	Resistance	Widerstand
R		Variable Resistor	Resistance Variable	Widerstand
T		Transformer	Transformateur	Transformer
TB		Terminal Block	Borne	Lösbare Klemme
X		Connector	Prise de Courant	Steckverbindung
K		Relay Contact Normally Open	Contact Normalement Ouvert	Schlierskontakt
K		Relay Contact Normally Closed	Contact Normalement Ferme	Oeffnungskontakt
K		Changeover Contact	Contact de Changement	Umschaltkontakt
		Shielded Wire	Cable blindé	Abgeschirmetes Kabel
TR		Transistor	Transistor	Transistor
M		Analog Meter	Instrument Analogue	Analog Meter
D		Diode	Diode	Diode
Z		Zener	Diode Zener	Zener
SCR		Thyristor	Thyristor	Thyristor
SW		Normally Open Maintained Switch	Interrupteur Normalement Maintenu Ouvert	Schrittschalter (Schliesser)
SW		Normally Closed Maintained Switch	Interrupteur Normalement Maintenu Fermé	Schrittschalter (Oeffner)
SW		Normally Closed Momentary Switch	Interrupteur Normalement Fermé Momentanement	Druckschalter (Oeffner)
SW		Normally Open Momentary Switch	Interrupteur Normalement Ouvert Momentanement	Druckschalter (Schliesser)
DP		Current Overload Device	Dispositif De Sûr Intensité	UeberstromschutzEinheit

**SECTION 12: ELECTRICAL DIAGRAMS****Drawing Number****Description**

9602014

6CP120/60-7.5 (120V, 50/60Hz) Electrical Schematic

9602015

6CP120/60-7.5 (220V, 50/60Hz) Electrical Schematic

## SECTION 13: PARTS ORDERING INFORMATION

Replacement parts are available from Phenix Technologies, Inc.

Changes to Phenix Technologies' products are sometimes made to accommodate improved components as they become available, and to give you the benefit of the latest technical improvements developed in our Engineering Department. It is, therefore, important when ordering parts to include the serial number of the unit as well as the part number of the replacement part.

When a request for parts is received at our office, a representative of Phenix Technologies will contact you to confirm the current price of the part being ordered. If a part you order has been replaced with a new or improved part, an applications engineer will contact you concerning any change in part number. Phenix will send a formal quotation. After customer confirmation of charges, a purchase order or other type of payment will be required so that we may complete processing and return the equipment to the customer.

Send orders for replacement parts to:

**Service Department  
Phenix Technologies, Inc.  
75 Speicher Drive  
Accident, Maryland 21520**

**Phone: (301) 746-8118  
Fax: (301) 895-5570  
E-mail: [info@phenixtech.com](mailto:info@phenixtech.com)  
web: [www.phenixtech.com](http://www.phenixtech.com)**

## SECTION 14: RETURNED MATERIAL

If for any reason it should become necessary to return this equipment to the factory, the Service Department of Phenix Technologies, Inc. must be given the following information:

Name Plate Information  
Model Number  
Serial Number  
Reason for Return  
Cause of Defect

If Phenix Technologies, Inc. deems return of the part appropriate; it will then issue an "Authorization for Return."

If return is not deemed advisable, other inspection arrangements will be made.

NOTE: Material received at this plant without the proper authorization shall be held as "Customer's Property" with no service until such time as the proper steps have been taken.

Your cooperation is requested in order to ensure prompt service.

## SECTION 15: PARTS LIST

Bubble No	Part Number	Description	Quantity
<b>CONTROL SECTION</b>			
C1-C4 (220V)	1096710	CAPACITOR, 60uF, 240VAC	4
C1-C4 (120V)	1098100	CAPACITOR, 120uF, 240VAC	4
CB1, CB2 (220 V)	1601317	15A, 2P CIRCUIT BREAKER	2
CB2 (120 V)	1601332	30A, 2P CIRCUIT BREAKER	1
CB1 (120V)	1601330	30A, 1P CIRCUIT BREAKER	1
D1-D5	1780025	1N4007 (1000VR, 1.0A)	5
F1, F2 (220 V)	1603601	FUSE, AGC-1, 250V	2
F1 (120V)	1603601	FUSE, AGC-1, 250V	1
F1, F2	1603920	FUSEHOLDER 3AG	1 or 2
K3	1705465	CONTACTOR, 30A/3P	1
K3 AUX	1701500	AUX CONTACT	1
LP1	1422153	LENS, CLEAR	1
LP1	1423300	LAMP SOCKET	1
LP1,4,SW1	1420163	LAMP, 24V, WHITE LED	3
M1, M2	31138800	PCB1388, CM PROTECTION BOARD	2
M1, M2	1506400	KNS 3 ½ DIGIT LCD, DMO-66T	2
M1, M2	1152152	10 PIN SOCKET CONN	2
M1, M2	1079909	RIBBON CABLE	6FT
MOV1 (220 V)	1606110	MOVISTOR, V275LA40A	1
MOV1 (120 V)	1606100	MOVISTOR, V130LA10A	1
P1	1151178	MAIN INPUT RECEPTACLE	1
P1	1151183	MALE CONTACT PINS	3
P2	1151179	OUTPUT TO TRANSFORMER RECEPTACLE	1
P2	1151185	FEMALE CONTACT PINS	2
PCB1387	31138709	CONTROL/METERING BD	1
R15	1761098	RESISTOR, 10kΩ, 2W LINEAR	1
R15-DIAL	1355910	DIAL	1
R15 KNOB	1355101	KNOB	1
R15 -CAP	1355102	PEAKED CAP	1
R15-KNOB	1355905	STATOR, BLACK	1
R16A-B	1720100	RESISTOR, 47Ω, ½ W	2
R17	1742190	RESISTOR, 10kΩ, 10W	1
SW1,11	1422153	LENS CLEAR	2
SW1	1860265	EAO SWITCH LATCHING 2 POLE	1
LP3	1420161	LAMP, 24V, GREEN LED	1
LP2	1420162	LAMP, 24V, RED LED	1
SW11	1860260	EAO SWITCH LATCHING 2 POLE	1
TMR1	1480120	PANEL MNT DIGITAL TIMER OMEGA #PTC-13	1
SW2/ LP2	1422150	LENS, RED	1
SW2,3,4	1860120	EAO SWITCH CONTACT, MOM 1 POLE	3
SW4/ LP4	1422148	LENS, BLUE	1
SW7	1866005	ROLLER LIMIT SWITCH, FORM C	1
SW3/ LP3	1422151	LENS, GREEN	1
SW5, SW9	1355310	KNOB	2
SW5	1863042	ROTARY SWITCH, 4P 2-6POS-S.	1
SW8	1860900	LATCHING MUSHROOM PSHBUTTON W / KEY	1
SW8	1862905	SIEMENS#3SB3400-OC,NC	1

## PARTS LIST

Bubble No	Part Number	Description	Quantity
<b>CONTROL SECTION (cont'd)</b>			
SW9	1863048	ROTARY SW, 4P, 2-3 POS, SHORTING	1
SW10	1861200	SWITCH w/PUSH TO TURN AND NC AUX,	1
SX1/WX1	1151147	EXT. INTLK. RECEPTACLE- CHASSIS	1
SX1/WX1	1151174	FEMALE PINS	6
SX1/WX1	50100018	SX1/WX1 PLUG	1
T1 (220 V)	1890234	1520 VARIABLE STACO	1
T1 (120 V)	1890230	1510 VARIABLE STACO	1
TMR1	1480120	PANEL TIMER	1
TX1	1151158	AMP 16 PIN CHASSIS CONNECTOR	1
TX1	1151172	MALE PINS	9
RED TEST LEAD	30080010	20FT RETURN CABLE	1
INPUT- CBL (220V)	30110028	POWER INPUT CABLE, 30 FT 14/3	1
INPUT- CBL (120V)	30110008	POWER INPUT CABLE, 30 FT 10/3	1
METER CBL (TX1)	30160001	20FT SIGNAL / METERING INTERCONNECT CABLE	1
POWER CBL(220V)	30110007	PWR INTERCONNECT CBL, 20FT, 10/2	1
POWER CBL(120V)	30110041	PWR INTERCONNECT CBL, 20FT, 8/2	1
<b>HIGH VOLTAGE SECTION</b>			
BP-GROUND	1351103	BINDING POST 459 GREEN	1
BP-GUARD	1351104	BINDING POST 459 WHITE	1
BP-RETURN	1351102	BINDING POST 459 RED	1
BP-SHORT BAR	1351110	SHORTING BAR	1
CONNECTOR CAPS	1151196	SIZE 17 CAP	2
D3001-4	1780066	TRANZORB, 10V	4
MOV3001-3 (220 V)	1606110	MOVISTOR, V275LA40A	3
MOV3001-3 (120 V)	1606100	MOVISTOR, V130LA10A	3
P3001	1151178	POWER CHASSIS CONNECTOR	1
P3001	1151183	MALE CONTACT PINS	2
PCB	1112231	PCB 1223	1
R3001A-C	1748351	RESISTOR. 150M $\Omega$ , 1%, 12W, SSX103	3
R3002A-B	1748351	RESISTOR. 150M $\Omega$ , 1%, 12W, SSX103	1
R3003, 3004	1722640	RESISTOR, 200k $\Omega$ , ¼ W, 1%	2
R3005A-C	1720600	RESISTOR, 300 $\Omega$ , ½ W	2
R3007	1722570	RESISTOR, 30k $\Omega$ , ¼ W 1%	1
R3008	1722087	RESISTOR, 3.0k $\Omega$ , ¼ W, 1%	1
R3009	1720600	RESISTOR, 300 $\Omega$ , ¼ W, 1%	1
R3010	1740185	RESISTOR, 30 $\Omega$ , 10W, 1%	1
SG3001-4	1605110	SPARKGAP, 90V	4
T3001	38342442	MAIN TRANSFORMER (120/220V), GO1-2442	1
TX1	1151158	TX1 CHASSIS CONNECTOR	1
TX1	1151170	20 GUAGE PINS	9

## SECTION 16: RECOMMENDED SPARE PARTS

Phenix Technologies recommends that the customer purchase and stock the following parts for normal maintenance of the unit. The recommended quantity should be sufficient to support the unit during normal operation.

If the unit will be operated at an isolated site for an extended period or will be subjected to unusual stresses, a larger quantity of parts should be stocked as spares. In such a case, contact your Phenix Technologies' sales representative for a recommendation.

Current prices may be obtained by contacting the Service Department at Phenix Technologies.

<u>Part Name</u>	<u>Computer Number</u>	<u>Recommended Quantity</u>
LCD Meter, KNS 3 ½ Digit DMO-66T	1506400	1
Limit Switch, 2HBA190-1 (SW7)	1866005	1
Switch, Mom., 1 Pole, 31-121.025 EAO (HV on, HV off, Reset)	1860120	1
Fuse, AGC-1 (F1,F2)	1603601	2
Rotary Switch –4P, 2-6 Pos.	1863042	1
Relay (K3)	1705465	1
Input Power Cable (120V)	30110008	1
Input Power Cable (220V)	30110028	1
Interconnect Power Cable (120V)	30110041	1
Interconnect Power Cable (220V)	30110007	1
Interconnect Signal / Metering cable	30160001	1
LED 24V White	1420163	3
LED 24V Red	1420162	1
LED 24V Green	1420161	1



## SECTION 17: CUSTOMER COMMENTS/SUGGESTIONS

Phenix Technologies made significant efforts to ensure that the information in this Operator's Manual is correct. If there are concerns or comments as you have used this information, Phenix Technologies appreciates any feedback.

Unit Serial Number:

Sect	Page(s)	Comment

Please return to Phenix Technologies, Engineering Department, 75 Speicher Drive, Accident, MD 21520 USA.

Phone: 1 (301) 746-8118; Fax: (301) 895-5570; or E-mail: [info@phenixtech.com](mailto:info@phenixtech.com)